

/// PARKSIDE

PERFORMANCE



LED WORK LIGHT PALS 100 A1

(GB) (CY)

LED WORK LIGHT

User manual

(HR)

LED REFLEKTOR

Upute za uporabu

(RO)

REFLECTOR DE LUCRU, CU LED

Instrucțiuni de utilizare

(GR) (CY)

ΠΡΟΒΟΛΕΑΣ ΕΡΓΑΣΙΑΣ LED

Οδηγίες χρήσης

(DE) (AT) (CH)

LED-ARBEITSSTRAHLER

Bedienungsanleitung

IAN 465735_2404

(HR) (RO) (GR)

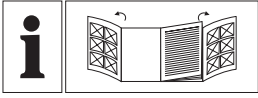

GB/CY	User manual	Page	5
HR	Upute za uporabu	Stranica	13
RO	Instrucțiuni de utilizare	Pagina	21
GR/CY	Οδηγίες χρήσης	Σελίδα	29
DE/AT/CH	Bedienungsanleitung	Seite	37

A

HG12251

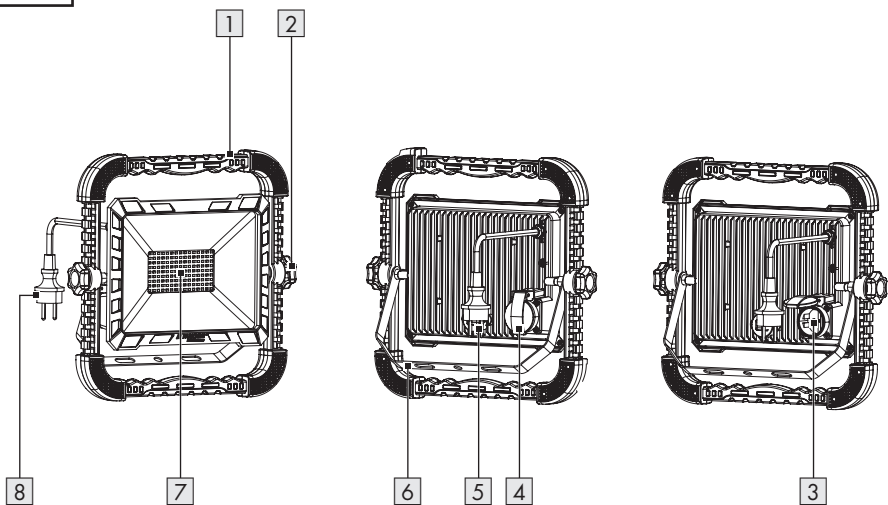
**B**

HG12251-FR

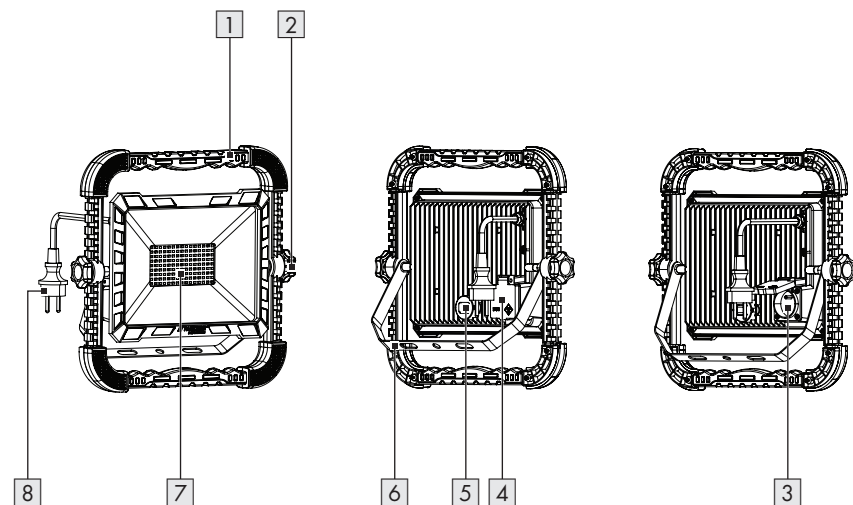

C

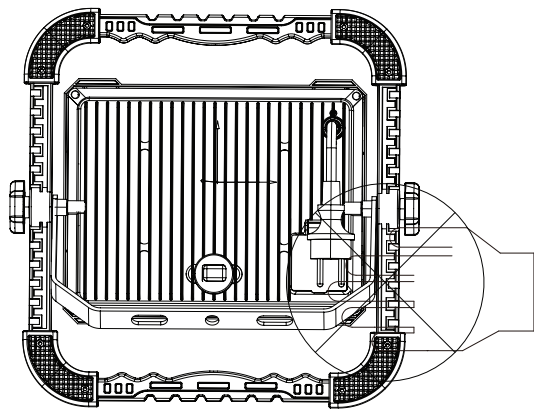



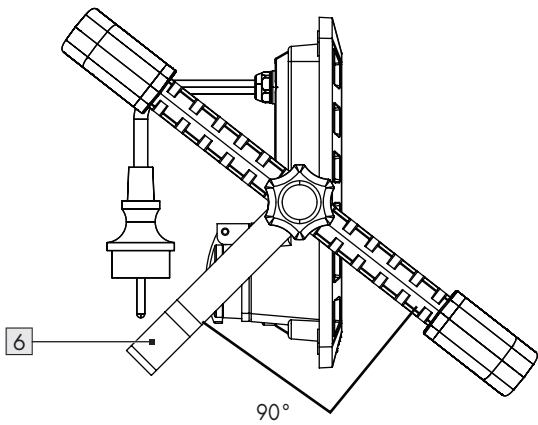











D



List of pictograms used	Page	6
Introduction	Page	7
Intended use	Page	7
Scope of delivery	Page	7
Parts list	Page	7
Technical data	Page	7
General safety instructions	Page	8
First use	Page	9
Unpacking the product	Page	9
Setting up the product	Page	10
Usage	Page	10
Switching the product on/off	Page	10
Connecting an external appliance to the socket-outlet	Page	10
Cleaning	Page	10
Disposal	Page	10
Warranty	Page	11
Warranty claim procedure	Page	11
Service	Page	12

List of pictograms used

	DANGER! – Designating a hazard with high risk, which will result in death or severe injury if not avoided (e.g. risk of suffocation)		Alternating current/voltage
	WARNING! – Designating a hazard with moderate risk, which can result in death or severe injury if not avoided (e.g. risk of electric shock)		Dust-protected + splash-proof (IP54) for LED work light (except socket-outlet)
	CAUTION! – Designating a hazard with low risk, which could result in minor or moderate injury if not avoided (e.g. risk of scalding)		Splash-proof (only socket-outlet)
	NOTICE! – Warns of possible damage to property/the product if not avoided (e.g. risk of short circuit)		Length of the mains cord: 3 m
	INFO: This symbol with the “Info” signal word offers additional useful information.		Product designed to withstand severe mechanical handling
	Minimum distance to illuminated material		Safety information Instructions for use
	Not suitable for household room illumination		CAUTION. Hot surface!
	CE mark indicates conformity with relevant EU directives applicable for this product.		

LED WORK LIGHT

● Introduction

We congratulate you on the purchase of your new product. You have chosen a high quality product. The instructions for use are part of the product. They contain important information concerning safety, use and disposal. Before using the product, please familiarise yourself with all of the safety information and instructions for use. Only use the product as described and for the specified applications. If you pass the product on to anyone else, please ensure that you also pass on all the documentation with it.

● Intended use

- This product is intended for use in rough conditions.
- This product is only suitable for private use in outdoor areas.
- This product is not intended for commercial use or for use in other applications.

● Technical data

Model:	HG12251	HG12251-FR
Input voltage:	230 V~, 50 Hz	
Total power consumption:	100 W	
Protection class:	I	
Power output via socket-outlet:	max. 2,500 W	
Dimensions:	approx. 36 cm × 35 cm × 8 cm	approx. 36 cm × 35 cm × 7 cm
Weight:	approx. 2,500 g	
1	dust-protected/splash-proof	
2	splash-proof	
3	mains plug for indoor use only	
4	only when socket-outlet cover closed (without mains plug inserted)	

-  This product is not suitable for household room illumination.

● Scope of delivery

- 1 LED work light
- 1 User manual

● Parts list

Before reading, unfold the page containing the illustrations and familiarise yourself with all functions of the product.

- 1 Handle
- 2 Star knob screw
- 3 Socket-outlet
- 4 Socket-outlet cover
- 5 On/off switch
- 6 Stand
- 7 LED panel
- 8 Mains cord with mains plug

Model:		HG12251	HG12251-FR
Projected area:		973 cm ²	
Certification:		GS	–
Degree of protection	Product (except socket-outlet):	IP54 ¹	IP54 ^{1,3}
	Socket-outlet:	IPX4 ²	IPX4 ^{2,4}
This product contains a light source of energy efficiency class “E”.			
¹ dust-protected/splash-proof ² splash-proof ³ mains plug for indoor use only ⁴ only when socket-outlet cover closed (without mains plug inserted)			



General safety instructions

BEFORE USING THE PRODUCT, FAMILIARISE YOURSELF WITH ALL OF THE SAFETY INFORMATION AND INSTRUCTIONS FOR USE! WHEN PASSING THIS PRODUCT ON TO OTHERS, ALSO INCLUDE ALL THE DOCUMENTS!



⚠ WARNING! DANGER TO LIFE AND RISK OF ACCIDENTS FOR INFANTS AND CHILDREN!

Never leave children unsupervised with the packaging material. Always keep children away from the packaging material.

- This product may be used by children aged 8 years and up, as well as by persons with reduced physical, sensory or mental capacities, or those lacking experience and/or knowledge provided they are supervised or instructed in the safe use of the product and they understand the associated risks. Do not allow children to play with the product. Cleaning and user maintenance must not be performed by children without supervision.

- This product is not a toy and should be kept out of the reach of children. Children are not aware of the dangers associated with handling electrical products.

⚠ DANGER! Risk of suffocation!

Children could swallow and choke on small included parts (e.g. screws). Keep children away from the work area during assembly.

- Do not use the product if you detect any type of damage.
- Never immerse the product in water or other liquids!
- Do not carry out any modifications or repairs to the product yourself. The built-in LED module and built-in LED driver cannot be replaced.
- If the LEDs fail at the end of their lives, the entire product must be replaced.
- The mains cord of this product cannot be replaced. If the mains cord is damaged, the product shall be destroyed.



Danger to life by electric shock

- Always check the product for damage before connecting it to the mains. Never use the product if it shows any signs of damage.
- Protect the mains cord against sharp edges, mechanical stresses and hot surfaces.
- Always unplug the mains plug from the socket-outlet before cleaning.
- Disconnect the product from the mains supply if it is not going to be used for some time (e.g. holiday).
- Verify that the mains voltage on site corresponds with the operating voltage required for the product (230 V~, 50 Hz), before you use it. Otherwise do not use the product.

⚠ CAUTION! Risk of burn injuries! To prevent burns, verify the product is switched off and has cooled down for at least 15 minutes before touching it. The product can become very hot.

- The accessible surface, is very hot when the lamp is operating.



FIRE HAZARD! Fit the product so that it is at least 1.0 metre away from the material to be illuminated. Excessive heat can result in a fire.

- **⚠ WARNING!** Do not turn on the light when the product is facing down to a combustible surface. The exposed surface may be overheated or ignited.
- Do not place burning candles or open fire on or near the product.
- Do not use the product near heat sources such as radiators or devices emitting heat.

- The product is only suited for use with the built-in LED control gear.
- The product continues to draw a small amount of power even if the product is off as long as product is connected to supply mains. To switch the product off completely, unplug the mains plug from the socket-outlet.
- The mains plug can only be connected with a corresponding socket-outlet with the same IP degree in order to keep the protective degree against dust/water.
- Luminaires shall not be connected after each other.
- The product can be hung up or it can be used on a flat, stable surface, e.g. floor or table.
- The product must not be used as a hand lamp.
- Do not mount the product to a wall or ceiling. The product may only be used as described in this user manual.

● **First use**

● **Unpacking the product**

1. Take the product out of the packaging and remove all packaging materials and plastic wrappings.
2. Check to make sure that all listed parts are included (see “Scope of delivery”).
3. Check whether the product and all parts are in good condition. If any damage or defect is detected, do not use the product, but follow the procedure described in chapter “Warranty”.

● Setting up the product

(Fig. C, D)

⚠ CAUTION! Risk of injury! Note the position of your hands whilst folding the stand **6** in or out. There is a risk of pinching your fingers.

1. Loosen both star knob screws **2**.
2. Fold out the stand **6** as far as it will go (approx. 90°).
3. Tighten both star knob screws **2**.
4. Place the product on a stable, horizontal surface.
5. Check the stability of the product.

● Usage

● Switching the product on/off

⚠ NOTICE! Risk of property damage! Do not move the mains cord **8** after connecting the mains plug to a socket-outlet. There is a risk that the product will slip or tip over.

- ① INFO:** Connect the mains plug **8** to an IPX4 socket-outlet during outdoor use.
- Connect the mains plug **8** to a suitable socket-outlet.
 - Switching on:** Press the on/off switch **5** to position **I** (normal brightness) or **II** (max. brightness).
 - Switching off:** Press the on/off switch **5** to position **O**.

● Connecting an external appliance to the socket-outlet

⚠ WARNING! Risk of fire! Do not connect any appliance with a total power consumption of more than 2,500 W.

⚠ WARNING! Risk of electric shock!

Water may enter the product if you connect an appliance featuring a non-waterproof mains plug. When using the product outdoors, make sure that the appliance to be connected to the socket-outlet **3** features a waterproof mains plug.

- The socket-outlet **3** is only IPX4 protected.
 - Only insert a corresponding IPX4 mains plug for outdoor use.
1. Open the socket-outlet cover **4**.
 2. Connect the mains plug of your appliance to the socket-outlet **3**.
 3. After use, disconnect the mains plug of your appliance from the socket-outlet **3**. Close the socket-outlet cover **4**.

● Cleaning

- Never immerse the product in water or other liquids. Otherwise the product can be damaged.
- Before cleaning:
 - Remove the mains plug **8** from the socket-outlet.
 - Allow the product to cool down.
 - Close the socket-outlet cover **4**.
- Clean the product with a lint-free, slightly moist cloth and mild cleaning agent.

● Disposal

The packaging is made entirely of recyclable materials, which you may dispose of at local recycling facilities.



Observe the marking of the packaging materials for waste separation, which are marked with abbreviations (a) and numbers (b) with following meaning: 1–7: plastics/20–22: paper and fibreboard/80–98: composite materials.

Product:



Contact your local refuse disposal authority for more details of how to dispose of your worn-out product.



To help protect the environment, please dispose of the product properly when it has reached the end of its useful life and not in the household waste. Information on collection points and their opening hours can be obtained from your local authority.

● Warranty

The product has been manufactured to strict quality guidelines and meticulously examined before delivery. In the event of material or manufacturing defects you have legal rights against the retailer of this product. Your legal rights are not limited in any way by our warranty detailed below.

The warranty for this product is 3 years from the date of purchase. The warranty period begins on the date of purchase. Keep the original sales receipt in a safe location as this document is required as proof of purchase.

Any damage or defects already present at the time of purchase must be reported without delay after unpacking the product.

Should the product show any fault in materials or manufacture within 3 years from the date of purchase, we will repair or replace it – at our choice – free of charge to you. The warranty period is not extended as a result of a claim being granted. This also applies to replaced and repaired parts.

This warranty becomes void if the product has been damaged, or used or maintained improperly.

The warranty covers material or manufacturing defects. This warranty does not cover product parts subject to normal wear and tear, thus considered consumables (e.g. batteries, rechargeable batteries, tubes, cartridges), nor damage to fragile parts, e.g. switches or glass parts.

● Warranty claim procedure

So that your request can be processed quickly, please observe the following instructions:

For all inquiries, please have the receipt and item number (IAN 465735_2404) ready as proof of purchase.

The article number can be taken from the identification label on the product, engraving on the product, the front cover of your manual (at the bottom left), or the sticker on the back or bottom of the product.

If malfunctions or other defects arise, first contact the service department indicated below by phone or email.

You can then send a product recorded as defective to the communicated service address postage-free, making sure to enclose proof of purchase (receipt) and information on the details of the defect and when it occurred.



You can download and view this and numerous other manuals at parkside-diy.com. This QR code takes you directly to parkside-diy.com. Choose your country and use the search screen to search for the operating instructions. Entering the item number (IAN) 465735_2404 takes you to the operating instructions for your item.

● Service

(GB) Service Great Britain

Tel.: 0800 0569216

E-Mail: owim@lidl.co.uk

(CY) Service Cyprus















Tel.: 8009 4211

E-Mail: owim@lidl.com.cy



Značenje korištenih piktograma/simbola	Stranica	14
Uvod	Stranica	15
Uvjeti korištenja	Stranica	15
Sadržaj isporuke.....	Stranica	15
Popis dijelova	Stranica	15
Tehnički podaci.....	Stranica	15
Opće sigurnosne napomene	Stranica	16
Početak rada	Stranica	17
Raspakirajte proizvod	Stranica	17
Postavljanje proizvoda	Stranica	17
Uporaba	Stranica	18
Uključivanje/isključivanje proizvoda	Stranica	18
Vanjski uređaj priključite u utičnicu.....	Stranica	18
Čišćenje	Stranica	18
Zbrinjavanje	Stranica	18
Jamstvo	Stranica	19
Postupak u slučaju koji je pokriven jamstvom	Stranica	19
Servis	Stranica	20

Značenje korištenih piktograma/simbola

	<p>OPASNOST! – Označava opasnost s visokom razinom rizika koja će, ako se ne izbjegne, rezultirati smrću ili ozbiljnom ozljedom (npr. gušenjem)</p>		<p>Izmjenična struja/napon</p>
	<p>UPOZORENJE! – Označava opasnost sa srednjom razinom rizika koja bi, ako se ne izbjegne, mogla dovesti do smrti ili ozbiljne ozljede (npr. opasnost od strujnog udara)</p>		<p>Zaštita od prašine i prskanja vode (IP54) kod LED reflektora (osim utičnice)</p>
	<p>OPREZ! – Označava opasnost s niskom razinom rizika koja bi, ako se ne izbjegne, mogla dovesti do manjih do umjerenih ozljeda (npr. opasnost od opekline)</p>		<p>Zaštita od prskanja vode (samo utičnica)</p>
	<p>PAŽNJA! – Upozorava na moguću štetu na imovini (npr. opasnost od kratkog spoja)</p>		<p>Duljina priključnog kabela: 3 m</p>
	<p>INFORMACIJE: Ovaj simbol s izrazom „Informacije“ pruža dodatne korisne informacije.</p>		<p>Proizvod je napravljen tako da podnosi jaka mehanička opterećenja</p>
	<p>Minimalna udaljenost do osvijetljenog materijala</p>		<p>Sigurnosne napomene Upute za rukovanje</p>
	<p>Nije prikladan za osvijetljenje prostorija u kućanstvu</p>		<p>OPREZ. Vruća površina!</p>
	<p>Oznaka CE potvrđuje sukladnost sa smjericama EU-a koje se primjenjuju na proizvod.</p>		

LED REFLEKTOR

● Uvod

Čestitamo vam na kupnji novog proizvoda. Ovom kupnjom odlučili ste se za visokokvalitetan proizvod. Uputa za uporabu je sastavni dio ovog proizvoda. Ona sadrži važne upute o sigurnosti, uporabi i uklanjanju otpada. Prije upotrebe proizvoda upoznajte se sa svim njegovim uputama za korištenje i sigurnosnim uputama. Koristite ovaj proizvod u skladu s navedenim uputama te u navedene svrhe. Ukoliko proizvod dajete nekoj drugoj osobi, predajte toj osobi također i sve upute.

● Uvjeti korištenja

- Ovaj proizvod je prikladan za uporabu u teškim uvjetima.
- Ovaj je proizvod prikladan samo za privatnu upotrebu na otvorenom.
- Ovaj proizvod nije namijenjen za komercijalnu niti drugu uporabu.

● Tehnički podaci

Model:	HG12251	HG12251-FR
Ulazni napon:	230 V~, 50 Hz	
Ukupna snaga:	100 W	
Razred zaštite:	I	
Izlazna snaga preko utičnice:	maks. 2500 W	
Dimenzije:	oko 36 cm × 35 cm × 8 cm	oko 36 cm × 35 cm × 7 cm
Težina:	pribl. 2500 g	
Projekcijska površina:	973 cm ²	
Certifikat:	GS	-
1 Zaštita od prašine/prskanja		
2 Zaštita od prskanja		
3 Mrežni utikač samo za uporabu u zatvorenom		
4 Samo kada je poklopac utičnice zatvoren (bez mrežnog utikača)		

-  Ovaj proizvod nije prikladan za osvjtljavanje prostorije u kućanstvu.

● Sadržaj isporuke

- 1 LED reflektor
- 1 Upute za uporabu

● Popis dijelova

Prije čitanja otvorite stranicu sa slikama i upoznajte se sa svim funkcijama proizvoda.

- 1 Ručka
- 2 Zvezdasti vijak
- 3 Utičnica
- 4 Poklopac utičnice
- 5 Prekidač za uključivanje/isključivanje
- 6 Postolje
- 7 LED ploča
- 8 Priključni kabel s mrežnim utikačem

Model:		HG12251	HG12251-FR
Vrsta zaštite	Proizvod (osim utičnice):	IP54 ¹	IP54 ^{1,3}
	Utičnica:	IPX4 ²	IPX4 ^{2,4}
Ovaj proizvod sadrži izvor svjetlosti razreda energetske učinkovitosti „E“.			
¹ Zaštita od prašine/prskanja ² Zaštita od prskanja ³ Mrežni utikač samo za uporabu u zatvorenom ⁴ Samo kada je poklopac utičnice zatvoren (bez mrežnog utikača)			



Opće sigurnosne napomene

PRIJE UPORABE PROIZVODA UPOZNAJTE SE SA SVIM UPUTAMA ZA UPORABU I SIGURNOSNIM NAPOMENAMA! AKO OVAJ PROIZVOD DAJETE NOVOM VLASNIKU, URUČITE MU I DOKUMENTACIJU!



⚠ UPOZORENJE! OPASNOST PO ŽIVOT I OPASNOST OD NEZGODA ZA NOVOROĐENČAD I DJECU!

Ne ostavljajte djecu s ambalažnim materijalom bez nadzora. Djecu držite podalje od ambalažnog materijala.

- Ovaj proizvod smiju koristiti djeca od 8 godina te osobe s ograničenim psihičkim, osjetilnim ili mentalnim sposobnostima ili osobe s nedostatkom iskustva i/ili znanja kada su pod nadzorom ili ako su upoznati s uputama o sigurnom korištenju proizvoda i ako shvaćaju povezane opasnosti. Ne dopustite djeci da se igraju s proizvodom. Djeca ne smiju čistiti niti održavati uređaj bez nadzora.
- Ovaj proizvod nije igračka i treba ga držati podalje od dohvata djece. Djeca nisu svjesna opasnosti povezanih s rukovanjem električnim uređajima.

⚠ OPASNOST! Opasnost od gušenja!

Djeca mogu progutati sitne dijelove (npr. vijke) i ugušiti se. Tijekom montaže djecu držite podalje od područja rada.

- Ne rabite proizvod ako je vidljivo oštećen.
- Proizvod nikada nemojte uranjati u vodu ili druge tekućine!
- Nemojte izvršiti nikakve promjene ni popravke na proizvodu. Ugrađeni LED modul i ugrađeni LED upravljač ne mogu se zamijeniti.
- Ako LED žarulje na kraju vijeka trajanja više ne rade, valja zamijeniti čitav proizvod.
- Nije moguće zamijeniti fleksibilni priključni kabel ovog proizvoda. Ako je priključni kabel oštećen, proizvod se mora zbrinuti.



Opasnost po život uslijed električnog udara

- Prije svakog priključivanja na električnu mrežu, provjerite ima li bilo kojih oštećenja na proizvodu. Proizvodom se nikada nemojte koristiti ukoliko utvrdite bilo kakva oštećenja.
- Zaštitite priključni kabel od oštih rubova, mehaničkih opterećenja ili vrućih površina.

- Prije čišćenja uvijek izvucite mrežni utikač iz utičnice.
- Odvojite proizvod od električne mreže ako ga nećete koristiti dulje vrijeme (npr. zbog odlaska na godišnji odmor).
- Prije uporabe provjerite odgovara li postojeći napon električne mreže potrebnom radnom naponu proizvoda (230 V~, 50 Hz). U suprotnom, nemojte koristiti proizvod.

⚠ OPREZ! Opasnost od opeklina!

Kako bi se izbjegle opeklina, uvjerite se da je proizvod isključen te da se hladi najmanje 15 minuta prije nego ga dodirnete. Proizvod može biti jako vruć.

- Dostupna površina postaje jako vruća kada se svjetlo koristi.

OPASNOST OD POŽARA!
 Proizvod postavite tako da bude udaljen od svjetlećeg materijala barem 1,0 metar. Prekomjerno oslobađanje topline može izazvati požar.

- **⚠ UPOZORENJE!** Ne uključujte svjetlo ako je proizvod usmjeren prema zapaljivoj površini. Zračena površina mogla bi se zagrijati ili zapaliti.
- Ne stavljajte goruće svijeće ili druge izvore otvorenog plamena na ili u blizini proizvoda.
- Proizvod nemojte upotrebljavati u blizini izvora topline, npr. radijatora ili drugih uređaja koji zrače toplinu.
- Proizvod se smije koristiti samo s ugrađenim prethodno spojenim LED-uređajem.
- Kada je spojen na izvor napajanja, proizvod troši manju količinu energije i kada je isključen. Za potpuno isključivanje mrežni utikač iskopčajte iz utičnice.

- Mrežni utikač može se priključiti samo na odgovarajuću utičnicu s istim IP stupnjem zaštite kako bi se održao stupanj zaštite od prašine/vode.
- Svjetla se ne smiju spajati jedna za drugom.
- Proizvod možete objesiti ili postaviti na ravnu, stabilnu površinu, npr. pod ili stol.
- Proizvod se ne smije koristiti kao ručna svjetiljka.
- Ne montirajte proizvod na zid ili strop. Proizvod se smije koristiti samo kako je opisano u ovim uputama za uporabu.

● **Početak rada**

● **Raspakiranje proizvoda**

1. Izvadite proizvod iz ambalažnog pakiranja. S proizvoda uklonite sav ambalažni materijal i zaštitne folije.
2. Provjerite postoje li svi dijelovi i je li opisani opseg isporuke potpun (vidi poglavlje „Sadržaj isporuke“).
3. Provjerite jesu li proizvod i svi njegovi dijelovi u dobrom stanju. Ako primijetite bilo kakvo oštećenje ili nedostatak, nemojte koristiti proizvod, već postupite kako je opisano u poglavlju „Jamstvo“.

● **Postavljanje proizvoda**

(Sl. C, D)

⚠ OPREZ! Opasnost od nezgode!

Obratite pažnju na položaj ruku dok sklapate ili rasklapate postolje **[6]**. Postoji opasnost od nagnječenja prstiju.

1. Otpustite oba zvjezdasta vijka **[2]**.
2. Otklopite postolje **[6]** dok se ne zaustavi (pribl. 90°).
3. Čvrsto zategnite zvjezdaste vijke **[2]**.

4. Stavite proizvod na stabilnu, vodoravnu površinu.
5. Provjerite stabilnost proizvoda.

● **Uporaba**

● **Uključivanje/isključivanje proizvoda**

⚠ PAŽNJA! Opasnost od materijalne štete! Ne pomičite priključni kabel **[8]** proizvoda nakon što ukopčate mrežni utikač u utičnicu. Proizvod bi mogao kliznuti ili prevrnuti se.

ⓘ INFORMACIJE: Ukopčajte mrežni utikač **[8]** u odgovarajuću IPX4 utičnicu kada proizvod koristite na otvorenom.

Mrežni utikač **[8]** povežite s prikladnom utičnicom.

Uključivanje: Pritisnite prekidač za uključivanje/isključivanje **[5]** u položaj **I** (normalna svjetlina) ili **II** (maksimalna svjetlina).

Isključivanje: Prekidač za uključivanje/isključivanje **[5]** pritisnite u položaj **O**.

● **Vanjski uređaj priključite u utičnicu**

⚠ UPOZORENJE! Opasnost od požara! Ne spajajte nijedan uređaj čija ukupna snaga prelazi 2500 W.

⚠ UPOZORENJE! Opasnost od električnog udara! Voda može ući u proizvod ako priključite uređaj s utikačem koji nije vodootporan. Ako koristite proizvod na otvorenom, provjerite ima li uređaj koji priključujete u utičnicu **[3]** vodootporan mrežni utikač.

■ Utičnica **[3]** zaštićena je samo u skladu s IPX4.

■ Ukopčajte samo odgovarajući IPX4 utikač za uporabu na otvorenom.

1. Otvorite poklopac utičnice **[4]**.
2. Ukopčajte mrežni utikač svog uređaja u utičnicu **[3]**.
3. Nakon svake uporabe isključite mrežni utikač vašeg uređaja iz utičnice **[3]**. Zatvorite poklopac utičnice **[4]**.

● **Čišćenje**

■ Proizvod nikada nemojte uranjati u vodu ili druge tekućine. Inače se proizvod može oštetiti.

Prije čišćenja:

- Izvucite mrežni utikač **[8]** iz utičnice.
- Pričekajte da se proizvod rashladi.
- Zatvorite poklopac utičnice **[4]**.

Očistite proizvod malo navlaženom krpom koja ne ostavlja dlačice i blagim deterdžentom.

● **Zbrinjavanje**

Ambalaža se sastoji od ekološki neškodljivih materijala koje možete zbrinuti na lokalnim mjestima za reciklažu.



Uvažavajte obilježavanje ambalaže za odvajanje otpada, ono je obilježeno s kraticama (a) i brojevima (b) sa slijedećim značenjem: 1–7: plastika/20–22: papir I karton/80–98: miješani materijali.

Proizvod:



O mogućnostima zbrinjavanja dotrajalog proizvoda možete se raspitati kod vaše općinske ili gradske uprave.



Zbog zaštite okoliša ne bacajte dotrajali proizvod u kućni otpad, već ga predajte stručnom zbrinjavanju. Informacije o mjestima za sakupljanje otpada i njihovom radnom vremenu možete dobiti pri Vašem nadležnom općinskom uredu.

● Jamstvo

Ovaj proizvod je pažljivo proizveden prema strogim smjernicama kvalitete i temeljito je ispitan prije isporuke. U slučaju pogreške u materijalu ili izradi, imate zakonska prava protiv prodavatelja proizvoda. Vaša zakonska prava ni na koji način nisu ograničena našom garancijom navedenom u nastavku.

Garancija za ovaj proizvod je 3 godine od datuma kupnje. Garantni rok počinje s datumom kupovine. Čuvajte originalni račun na sigurnom mjestu jer je ovaj dokument potreban kao dokaz kupnje.

Sva oštećenja ili nedostaci koji su već prisutni u trenutku kupnje moraju se prijaviti odmah nakon raspakiranja proizvoda.

Ako se u roku od 3 godine od datuma kupnje pokaže da je proizvod neispravan u materijalu ili izradi, mi ćemo ga, po našem izboru, besplatno popraviti ili zamijeniti. Garantni rok se ne produljuje odobrenim zahtjevom za garanciju. To vrijedi i za zamijenjene i popravljene dijelove.

Ova garancija ne vrijedi ako je proizvod bio oštećen ili nepropisno korišten ili održavan.

Garancija pokriva greške u materijalu i proizvodnji. Ova se garancija ne odnosi na dijelove proizvoda koji su podložni uobičajenom habanju, te se stoga smatraju potrošnim dijelovima (npr. baterije, punjive baterije, crijeva, spremnici s tintom), niti na oštećenja lomljivih dijelova, npr. prekidača ili dijelova od stakla.

U slučaju manjeg popravka jamstveni rok se produljuje onoliko koliko je kupac bio lišen uporabe stvari.

Međutim, kad je zbog neispravnosti stvari izvršena njezina zamjena ili njezin bitni popravak, jamstveni rok počinje teći ponovno od zamjene, odnosno od vraćanja popravljene stvari.

Ako je zamijenjen ili bitno popravljen samo neki dio stvari, jamstveni rok počinje teći ponovno samo za taj dio.

● Postupak u slučaju koji je pokriven jamstvom

Kako bismo osigurali brzu obradu vašeg zahtjeva, slijedite upute u nastavku:

Za sve upite kao dokaz o kupnji pripremite račun i broj artikla (IAN 465735_2404).

Broj artikla možete pronaći na tipskoj pločici na proizvodu, gravuri na proizvodu, naslovnici vaših uputa (dolje lijevo) ili naljepnici na stražnjoj i donjoj strani proizvoda.

Ako se pojave funkcionalni kvarovi ili drugi nedostaci, prvo se obratite servisnoj odjelu koji je naveden u nastavku telefonski ili e-poštom.

Proizvod za koji je utvrđen kvar, uz prilaganje potvrde o kupnji (računa) i informacijama o nedostacima i kada su nastali, možete poslati na adresu servisa kojega ste obavijestili bez poštarine.



Ove i mnoge druge priručnike možete pregledati i preuzeti na stranici parkside-diy.com. Ovaj QR kod vodi vas izravno na našu stranicu parkside-diy.com. Odaberite svoju zemlju i putem tražilice potražite upute za uporabu. Unosom broja artikla (IAN) 465735_2404 dospjet ćete do uputa za uporabu za svoj artikl.

● **Servis**

 **Servis Hrvatska**















Tel.: 0800806355

E-Mail: owim@lidl.hr



Lista pictogramelor/simbolurilor utilizate	Pagina	22
Introducere	Pagina	23
Utilizarea conform destinației	Pagina	23
Volumul livrării	Pagina	23
Lista pieselor	Pagina	23
Date tehnice	Pagina	23
Indicații generale de siguranță	Pagina	24
Punerea în funcțiune	Pagina	25
Despachetarea produsului	Pagina	25
Amplasarea produsului	Pagina	26
Utilizare	Pagina	26
Pornirea sau oprirea produsului	Pagina	26
Conectarea unui aparat extern la priză	Pagina	26
Curățarea	Pagina	26
Înlăturare	Pagina	26
Garanție	Pagina	27
Modul de desfășurare în caz de garanție	Pagina	28
Service	Pagina	28

Lista pictogramelor/simbolurilor utilizate

	<p>PERICOL! – Indică un pericol cu grad ridicat de risc care, dacă nu este evitat, are ca urmare moartea sau o rănire gravă (de ex. pericol de sufocare)</p>		<p>Curent/tensiune alternativă</p>
	<p>AVERTISMENT! – Indică un pericol cu grad mediu de risc care, dacă nu este evitat, poate avea ca urmare moartea sau o rănire gravă (de ex. pericol de electrocutare)</p>		<p>Reflectorul de lucru, cu LED este protejat împotriva prafului parțial și a stropirii cu apă din toate direcțiile (IP54) (cu excepția prizei)</p>
	<p>PRECAUȚIE! – Indică un pericol cu grad scăzut de risc care, dacă nu este evitat, poate avea ca urmare o rănire ușoară până la medie (de ex. pericol de opărire)</p>		<p>Protejat împotriva stropirii cu apă din toate direcțiile (numai prize)</p>
	<p>ATENȚIE! – Avertizează cu privire la posibile daune materiale (de ex., pericol de scurtcircuitare)</p>		<p>Lungimea cablului de alimentare: 3 m</p>
	<p>INFORMAȚII: Acest simbol având cuvântul de semnalizare „Informații” oferă mai multe informații utile.</p>		<p>Produsul este proiectat pentru a rezista la sarcini mecanice puternice</p>
	<p>Distanță minimă față de materialul care trebuie iluminat</p>		<p>Indicații de siguranță Instrucțiuni de manevrare</p>
	<p>Nu este potrivit pentru iluminarea încăperilor din gospodărie</p>		<p>PRECAUȚIE. Suprafață fierbinte!</p>
	<p>Semnul CE confirmă conformitatea cu directivele UE referitoare la produs.</p>		

REFLECTOR DE LUCRU, CU LED

● Introducere

Vă felicităm pentru achiziționarea noului dumneavoastră produs. Ați ales un produs de înaltă calitate. Manualul de utilizare reprezintă o parte integrantă a acestui produs. Acesta conține informații importante referitoare la siguranță, la utilizare și la eliminarea ca deșeu. Înainte de utilizarea acestui produs, familiarizați-vă mai întâi cu instrucțiunile de utilizare și de siguranță. Folosiți produsul numai în modul descris și numai în domeniile de utilizare indicate. Predați toate documentele aferente în cazul în care înstrăinați produsul.

● Utilizarea conform destinației

- Acest produs este potrivit pentru utilizarea în condiții dificile.
- Acest produs se potrivește exclusiv pentru utilizarea privată în zone exterioare.

- Acest produs nu este destinat utilizării industriale sau altor aplicații.

-  Acest produs nu este potrivit pentru iluminarea încăperilor din gospodărie.

● Volumul livrării

1 Reflector de lucru, cu LED

1 Instrucțiuni de utilizare

● Lista pieselor

Înainte de citire desfaceți pagina cu figuri și familiarizați-vă cu toate funcțiile produsului.

- 1 Mâner
- 2 Buton stea cu șurub
- 3 Priză
- 4 Capac priză
- 5 Întrerupător Pornit/Oprit
- 6 Picior suport
- 7 Panou cu LED
- 8 Cablu de alimentare cu ștecher

● Date tehnice

Model:	HG12251	HG12251-FR
Tensiune de intrare:	230 V~, 50 Hz	
Consum total de putere:	100 W	
Clasă de protecție:	I	
Putere de ieșire prin priză:	max. 2500 W	
Dimensiuni:	cca. 36 cm × 35 cm × 8 cm	cca. 36 cm × 35 cm × 7 cm
Greutate:	cca. 2500 g	
1	Protecție împotriva prafului/protecție contra stropirii	
2	Protecție contra stropirii	
3	Ștecher doar pentru folosire în interior	
4	Numai când capacul prizei este închis (fără ștecher introdus)	

Model:		HG12251	HG12251-FR
Suprafață de proiectare:		973 cm ²	
Certificare:		GS	–
Tip de protecție	Produs (în afară de priză):	IP54 ¹	IP54 ^{1,3}
	Priză:	IPX4 ²	IPX4 ^{2,4}
Acest produs conține o sursă de lumină cu clasa de eficiență energetică „E”.			
1 Protecție împotriva prafului/protecție contra stropirii			
2 Protecție contra stropirii			
3 Ștecher doar pentru folosire în interior			
4 Numai când capacul prizei este închis (fără ștecher introdus)			



Indicații generale de siguranță

FAMILIARIZAȚI-VĂ CU TOATE INSTRUCȚIUNILE DE FOLOSIRE ȘI DE SIGURANȚĂ ÎNAINTE DE UTILIZAREA PRODUSULUI! DACĂ DAȚI PRODUSUL ALTEI PERSOANE, ATAȘAȚI TOATE DOCUMENTELE!



⚠️ AVERTISMENT! PERICOL DE MOARTE ȘI ACCIDENTE PENTRU SUGARI ȘI COPII!

Nu lăsați copiii nesupravegheați cu materialul de ambalare. Nu lăsați materialul de ambalare la îndemâna copiilor.

- Acest produs poate fi folosit de copiii peste 8 ani și de persoanele cu capacități fizice, senzoriale sau mentale limitate sau fără experiență și/sau fără cunoștințe, dacă aceștia sunt supravegheați sau au primit instrucțiuni în ceea ce privește utilizarea în siguranță a produsului și au înțeles pericolele care rezultă din aceasta. Nu lăsați copiii să se joace cu produsul. Curățarea și întreținerea nu trebuie efectuate de către copii fără supraveghere.

- Acest produs nu este o jucărie și nu trebuie lăsat la îndemâna copiilor. Copiii nu sunt conștienți de pericolele asociate cu aparatele electrice.



PERICOL! Risc de sufocare! Copiii ar putea înghiți piesele mici livrate (de ex. șuruburi) și s-ar putea sufoca. Țineți copiii la distanță de zona de lucru în timpul montajului.

- Nu folosiți produsul dacă aceasta prezintă deteriorări vizibile.
- Nu scufundați niciodată produsul în apă sau în alte lichide!
- Nu faceți reparații sau modificări la produs. Modulul LED încorporat și driverul LED încorporat nu pot fi înlocuite.
- Dacă la sfârșitul perioadei de utilizare LED-urile nu mai funcționează, întregul produs trebuie înlocuit.
- Cablul de alimentare al produsului nu poate fi înlocuit. Dacă s-a deteriorat cablul de alimentare, produsul trebuie aruncat.



Pericol de moarte prin electrocutare

- Verificați produsul pentru orice deteriorare înainte de fiecare conectare la rețea. Nu folosiți niciodată produsul dacă constatați orice deteriorări.
- Protejați cablul de alimentare de muchii ascuțite, sarcini mecanice și suprafețe fierbinți.
- Înainte de curățare scoateți ștecherul din priză.
- Decuplați produsul de la rețea, dacă nu îl folosiți un timp îndelungat (de ex. vacanță).
- Înainte de utilizare, asigurați-vă că tensiunea existentă a rețelei corespunde tensiunii de funcționare necesare a produsului (230 V~, 50 Hz). Nu utilizați produsul în caz că nu este așa.

⚠ PRECAUȚIE! Risc de arsuri! Pentru a evita arsurile, asigurați-vă că produsul este deconectat și s-a răcit timp de minim 15 minute, înainte să îl atingeți. Produsul se poate înfierbânta foarte tare.

- Suprafața accesibilă devine foarte fierbinte când lampa este în funcțiune.



PERICOL DE INCENDIU! Așezați produsul în așa fel încât el să se afle la cel puțin 1,0 metru de materialul care trebuie iluminat. Dezvoltarea excesivă de căldură poate duce la un incendiu.

- **⚠ AVERTISMENT!** Nu aprindeți lumina dacă produsul este îndreptat spre o suprafață inflamabilă. Suprafața iluminată se poate supraîncălzi sau se poate aprinde.
- Nu puneți lumânări aprinse sau alte flăcări deschise pe sau în apropierea produsului.

- Nu folosiți produsul în apropierea surselor de căldură, de ex. radiatoare sau alte aparate care emit căldură.
- Produsul trebuie utilizat numai cu limitatorul de curent LED încorporat.
- Produsul încă mai consumă puțină energie chiar și atunci când produsul este oprit, dar cu alimentarea electrică conectată. Pentru deconectare completă, scoateți ștecherul din priză.
- Ștecherul poate fi conectat numai la o priză cu același grad de protecție IP pentru a menține gradul de protecție împotriva prafului/appei.
- Lămpile nu trebuie conectate una după alta.
- Puteți fie să agățați produsul, fie să îl așezați pe o suprafață plană și stabilă, de exemplu pe podea sau pe masă.
- Produsul nu trebuie utilizat ca lampă de mână.
- Nu montați produsul pe un perete sau tavan. Produsul poate fi utilizat numai în conformitate cu descrierea din aceste instrucțiuni de utilizare.

● Punerea în funcțiune

● Despachetarea produsului

1. Scoateți produsul din ambalaj. Îndepărtați toate materialele de ambalare și folia de protecție.
2. Verificați dacă toate componentele sunt prezente și dacă volumul livrării descris este complet (vezi „Volumul livrării”).
3. Verificați dacă produsul și toate componentele sunt în stare bună. Dacă constatați o deteriorare sau un defect, nu utilizați produsul, ci procedați așa cum este descris în capitolul „Garanție”.

● Amplasarea produsului

(Fig. C, D)

⚠ PRECAUȚIE! Risc de rănire! Acordați atenție poziției mâinilor pe măsură ce retractați sau deschideți piciorul suport [6]. Există riscul de strivire a degetelor.

1. Slăbiți ambele butoane stea cu șurub [2].
2. Deschideți piciorul suport [6] până la limită (ca. 90°).
3. Strângeți ambele butoane stea cu șurub [2].
4. Așezați produsul pe o suprafață stabilă, orizontală.
5. Verificați stabilitatea produsului.

● Utilizare

● Pornirea sau oprirea produsului

⚠ ATENȚIE! Pericol de pagube materiale! Nu mutați cablul de alimentare [8] al produsului, după ce ați conectat ștecherul la o priză. Există riscul ca produsul să alunece sau să se răstoarne.

- i INFORMAȚII:** Conectați ștecherul [8] la o priză IPX4 dacă utilizați produsul în exterior.
- Introduceți ștecherul [8] într-o priză potrivită.
 - Pornirea:** Apăsați întrerupătorul Pornit/Oprit [5] în poziția **I** (luminozitate normală) sau în poziția **II** (luminozitate max.).
 - Oprirea:** Apăsați întrerupătorul Pornit/Oprit [5] în poziția **O**.

● Conectarea unui aparat extern la priză

⚠ AVERTISMENT! Risc de incendiu! Nu conectați niciun aparat, al cărui consum total de putere depășește 2500 W.

⚠ AVERTISMENT! Risc de electrocutare! Apa poate pătrunde în produs în cazul în care conectați un aparat cu un conector care nu este rezistent la apă. Dacă utilizați produsul în exterior, asigurați-vă că aparatul care urmează să fie conectat la priză [3] este dotat cu un ștecher rezistent la apă.

- Priza [3] este protejată numai conform gradului de protecție IPX4.
- Conectați numai un conector IPX4 corespunzător pentru exterior.

1. Deschideți capacul prizei [4].
2. Introduceți ștecherul aparatului în priză [3].
3. Scoateți ștecherul aparatului dvs. din priză [3] după utilizare. Închideți capacul prizei [4].

● Curățarea

- Nu scufundați niciodată produsul în apă sau în alte lichide. În caz contrar produsul poate fi deteriorat.
- Înainte de curățare:
 - Scoateți ștecherul [8] din priză.
 - Lăsați produsul să se răcească.
 - Închideți capacul prizei [4].
- Curățați produsul cu o lavetă fără scame, ușor umezită și cu un detergent delicat.

● Înlăturare

Ambalajul este produs din material ecologic care pot fi eliminate la punctele locale de reciclare.



Respectați marcajul materialelor de ambalaj pentru eliminarea deșeurilor, acestea sunt marcate de abrevierile (a) și cifrele (b) cu următoarea semnificație: 1–7: plastice/20–22: hârtie și carton/80–98: substanțe de conexiune.

Produsul:



Puteți obține informații despre posibilitățile de eliminare a produsului de la administrația locală.



Pentru a proteja mediul înconjurător nu eliminați produsul dumneavoastră la gunoiul menajer atunci când nu mai poate fi folosit, ci predați-l la un punct de colectare. Vă puteți informa cu privire la punctele de colectare și orarul acestora de la administrația competentă.

● Garanție

Produsul a fost fabricat cu atenție, conform unor standarde stricte de calitate și verificat temeinic înainte de livrare. În caz de defecțiuni de material sau de fabricație aveți drepturi legale față de vânzătorul produsului. Drepturile dumneavoastră legale nu sunt limitate în niciun fel de garanția menționată mai jos.

Garanția pentru aceste produs este 3 ani începând de la data achiziției. Durata garanției începe la data achiziției. Păstrați chitanța originală la un loc sigur, deoarece acest document este necesar pentru dovada achiziției.

Toate defecțiunile sau deteriorările care sunt deja existente la momentul achiziției, trebuie anunțate imediat după despachetarea produsului.

Dacă în decurs de 3 ani de la achiziția produsului apare un defect de material sau de fabricație, vă reparăm sau înlocuim gratuit produsul la alegerea noastră. Durata de garanție nu se prelungește după aprobarea unei cerințe de garanție. Aceasta este valabil și pentru piesele schimbate și reparate.

Această garanție se stinge dacă produsul este deteriorat, utilizat sau întreținut în mod necorespunzător.

Garanția acoperă defectele de material și de producție. Această garanție nu acoperă piesele componente ale produsului, care prezintă urme normale de uzură și care sunt considerate piese de schimb (de ex.: baterii, acumulatori, furtunuri, cartușe de vopsea) și nici deteriorările la nivelul pieselor casante, de exemplu întrerupătoare sau piese fabricate din sticlă.

Timpul de nefuncționare din cauza lipsei de conformitate apărute în cadrul termenului de garanție prelungeste termenul de garanție legală de conformitate și cel al garanției comerciale și curge, după caz, din momentul la care a fost adusă la cunoștința vânzătorului lipsa de conformitate a produsului sau din momentul prezentării produsului la vânzător/unitatea service până la aducerea produsului în stare de utilizare normală și, respectiv, al notificării în scris în vederea ridicării produsului sau predării efective a produsului către consumator.

Produsele de folosință îndelungată care înlocuiesc produse defecte în cadrul termenului de garanție vor beneficia de un nou termen de garanție care curge de la data preschimbării produsului.

● Modul de desfășurare în caz de garanție

Pentru a putea asigura o procesare rapidă a cererii dumneavoastră, vă rugăm să urmați următoarele indicații:

Vă rugăm să țineți la îndemână bonul de casă și numărul articolului (IAN 465735_2404) ca dovadă pentru achiziția dumneavoastră.

Vă rugăm să luați numărul de produs de pe plăcuța cu tipul de construcție de pe produs, gravura de pe produs, pagina principală a instrucțiunii de utilizare (jos, stânga) sau de pe spatele sau fundul produsului.

În cazul în care, apar erori de funcționare sau alte defecțiuni, contactați mai întâi prin telefon sau prin e-mail, departamentul de service menționat în continuare.

Dumneavoastră puteți să expediați atunci un produs considerat ca fiind defect, adăugând chitanța de plată (bonul de casă) și menționând, în ce constă defecțiunea și când a apărut aceasta, fără cheltuieli poștale, la adresa de service comunicată.



La parkside-diy.com puteți să vedeți și să descărcați acest manual și multe altele. Cu acest cod QR ajungeți direct la parkside-diy.com. Selectați țara dumneavoastră și căutați manualele de utilizare prin motorul de căutare. Dacă introduceți numărul de articol (IAN) 465735_2404 ajungeți la manualul de utilizare pentru articolul dumneavoastră.

● Service

RO Service România

Tel.: 0800890239

E-Mail: owim@lidl.ro



Λίστα χρησιμοποιούμενων εικονογραμμάτων/συμβόλων	Σελίδα	30
Εισαγωγή	Σελίδα	31
Προβλεπόμενη χρήση	Σελίδα	31
Περιεχόμενο συσκευασίας	Σελίδα	31
Λίστα εξαρτημάτων	Σελίδα	31
Τεχνικά δεδομένα	Σελίδα	31
Γενικές υποδείξεις ασφαλείας	Σελίδα	32
Θέση σε λειτουργία	Σελίδα	34
Αποσυσκευασία προϊόντος	Σελίδα	34
Τοποθέτηση του προϊόντος	Σελίδα	34
Χρήση	Σελίδα	34
Ενεργοποίηση και απενεργοποίηση του προϊόντος	Σελίδα	34
Σύνδεση εξωτερικής συσκευής στην πρίζα	Σελίδα	34
Καθαρισμός	Σελίδα	35
Απόσυρση	Σελίδα	35
Εγγύηση	Σελίδα	35
Διεκπεραίωση της εγγύησης	Σελίδα	36
Σέρβις	Σελίδα	36

Λίστα χρησιμοποιούμενων εικονογραμμάτων/συμβόλων

	<p>ΚΙΝΔΥΝΟΣ! – Υποδεικνύει έναν κίνδυνο υψηλού βαθμού ο οποίος, αν δεν αποφευχθεί, μπορεί να προκαλέσει θάνατο ή σοβαρό τραυματισμό (π.χ. κίνδυνος πνιγμού)</p>		<p>Εναλλασσόμενο ρεύμα/τάση</p>
	<p>ΠΡΟΕΙΔΟΠΟΙΗΣΗ! – Υποδεικνύει έναν κίνδυνο μέτριου βαθμού ο οποίος, αν δεν αποφευχθεί, μπορεί να προκαλέσει θάνατο ή σοβαρό τραυματισμό (π.χ. κίνδυνος ηλεκτροπληξίας)</p>		<p>Με προστατευτικό σκόνης/πιτσιλίσματος (IP54) για προβολέα εργασίας LED (εκτός από την πρίζα)</p>
	<p>ΠΡΟΣΟΧΗ! – Υποδεικνύει έναν κίνδυνο χαμηλού βαθμού ο οποίος, αν δεν αποφευχθεί, μπορεί να προκαλέσει ελαφρύ ή μέτριο τραυματισμό (π.χ. κίνδυνος εγκαύματος)</p>		<p>Με προστατευτικό πιτσιλίσματος (μόνο στην πρίζα)</p>
	<p>ΕΠΙΦΥΛΑΚΗ! – Προειδοποιεί για πιθανές υλικές ζημιές (π.χ. κίνδυνος βραχυκυκλώματος)</p>		<p>Μήκος καλωδίου τροφοδοσίας: 3 m</p>
	<p>ΠΛΗΡΟΦΟΡΙΕΣ: Αυτό το σύμβολο με την προειδοποιητική λέξη «Πληροφορίες» παρέχει περισσότερες χρήσιμες πληροφορίες.</p>		<p>Το προϊόν έχει σχεδιαστεί για αντοχή σε έντονη μηχανική επιβάρυνση</p>
	<p>Ελάχιστη απόσταση από το φωτιζόμενο αντικείμενο</p>		<p>Υποδείξεις ασφαλείας Οδηγίες χειρισμού</p>
	<p>Δεν ενδείκνυται για χρήση ως φωτιστικό χώρου σε νοικοκυριά</p>		<p>ΠΡΟΣΟΧΗ. Πολύ θερμή επιφάνεια!</p>
	<p>Το σύμβολο CE επιβεβαιώνει τη συμβατότητα με τις οδηγίες της ΕΕ που ισχύουν για το προϊόν.</p>		

ΠΡΟΒΟΛΕΑΣ ΕΡΓΑΣΙΑΣ LED

● Εισαγωγή

Σας συγχάιρουμε για την αγορά του νέου σας προϊόντος. Επιλέξατε ένα προϊόν υψηλών προδιαγραφών. Οι οδηγίες χρήσης είναι μέρος αυτού του προϊόντος. Περιέχουν σημαντικές πληροφορίες σχετικά με την ασφάλεια, το χειρισμό και την απόρριψη. Πριν τη χρήση του προϊόντος εξοικειωθείτε με όλες τις οδηγίες χρήσης και ασφαλείας. Χρησιμοποιείτε το προϊόν μόνο με τον τρόπο που περιγράφεται και για τον τομέα εφαρμογής που αναφέρεται. Σε περίπτωση μεταβίβασης του προϊόντος σε τρίτους παραδώστε μαζί και όλα τα έγγραφα.

● Προβλεπόμενη χρήση

- Αυτό το προϊόν ενδείκνυται για χρήση σε σκληρές συνθήκες.
- Αυτό το προϊόν ενδείκνυται αποκλειστικά για ιδιωτική χρήση σε εξωτερικούς χώρους.
- Το προϊόν δεν προορίζεται για επαγγελματική χρήση ή άλλες εφαρμογές.

● Τεχνικά δεδομένα

Μοντέλο:	HG12251	HG12251-FR
Τάση εισόδου:	230 V~, 50 Hz	
Συνολική ισχύς εισόδου:	100 W	
Κατηγορία προστασίας:	I	
Ισχύς εξόδου μέσω της πρίζας:	μέγ. 2500 W	
Διαστάσεις:	περ. 36 cm × 35 cm × 8 cm	περ. 36 cm × 35 cm × 7 cm
1 Προστατευτικό σκόνης/πιτσιλίσματος		
2 Προστατευτικό πιτσιλίσματος		
3 Φις μόνο για χρήση σε εσωτερικούς χώρους		
4 Μόνο με το κάλυμμα πρίζας κλειστό (χωρίς συνδεδεμένο φις)		

-  Αυτό το προϊόν δεν είναι κατάλληλο για φωτισμό χώρου σε νοικοκυριό.

● Περιεχόμενο συσκευασίας

1 Προβολέας εργασίας LED

1 Οδηγίες χρήσης

● Λίστα εξαρτημάτων

Πριν διαβάσετε τις οδηγίες, ξεδιπλώστε τη σελίδα με τις εικόνες και εξοικειωθείτε με τις λειτουργίες του προϊόντος.

- 1 Λαβή
- 2 Κοχλίας με αστεροειδή λαβή
- 3 Πρίζα
- 4 Κάλυμμα πρίζας
- 5 Διακόπτης ενεργοποίησης/ απενεργοποίησης
- 6 Πόδι στήριξης
- 7 Πίνακας LED
- 8 Καλώδιο τροφοδοσίας με φις

Μοντέλο:		HG12251	HG12251-FR
Βάρος:		περ. 2500 g	
Επιφάνεια προβολής:		973 cm ²	
Πιστοποίηση:		GS	–
Τύπος προστασίας	Προϊόν (εκτός από την πρίζα):	IP54 ¹	IP54 ^{1,3}
	Πρίζα:	IPX4 ²	IPX4 ^{2,4}
Αυτό το προϊόν διαθέτει μια φωτεινή πηγή κατηγορίας ενεργειακής απόδοσης «E».			
<ol style="list-style-type: none"> 1 Προστατευτικό σκόνης/πιτσιλίσματος 2 Προστατευτικό πιτσιλίσματος 3 Φις μόνο για χρήση σε εσωτερικούς χώρους 4 Μόνο με το κάλυμμα πρίζας κλειστό (χωρίς συνδεδεμένο φις) 			



Γενικές υποδείξεις ασφαλείας

ΠΡΙΝ ΤΗ ΧΡΗΣΗ ΤΟΥ ΠΡΟΪΟΝΤΟΣ ΕΞΟΙΚΕΙΩΘΕΙΤΕ ΜΕ ΟΛΕΣ ΤΙΣ ΥΠΟΔΕΙΞΕΙΣ ΑΣΦΑΛΕΙΑΣ ΚΑΙ ΤΙΣ ΟΔΗΓΙΕΣ ΧΡΗΣΗΣ! ΑΝ ΔΩΣΕΤΕ ΤΟ ΠΡΟΪΟΝ ΣΕ ΑΛΛΑ ΑΤΟΜΑ, ΔΩΣΤΕ ΜΑΖΙ ΚΑΙ ΟΛΑ ΤΑ ΕΓΓΡΑΦΑ!



ΠΡΟΕΙΔΟΠΟΙΗΣΗ! **ΚΙΝΔΥΝΟΣ ΓΙΑ ΤΗ ΖΩΗ ΚΑΙ ΚΙΝΔΥΝΟΣ ΑΤΥΧΗΜΑΤΟΣ ΓΙΑ ΒΡΕΦΗ ΚΑΙ ΠΑΙΔΙΑ!**

Μην αφήνετε τα παιδιά να παίζουν με τα υλικά συσκευασίας χωρίς επίβλεψη. Μην επιτρέπετε στα παιδιά να πλησιάζουν τα υλικά συσκευασίας.

- Το προϊόν μπορεί να χρησιμοποιηθεί από παιδιά ηλικίας 8 ετών και πάνω και από άτομα με περιορισμένες φυσικές, αισθητηριακές ή πνευματικές δυνατότητες ή με έλλειψη εμπειρίας ή/και γνώσεων, εφόσον επιτηρούνται ή έχουν λάβει οδηγίες ως προς την ασφαλή χρήση του προϊόντος και κατανοούν τους σχετικούς κινδύνους. Μην αφήνετε τα παιδιά να παίζουν με το προϊόν. Οι εργασίες καθαρισμού και

συντήρησης δεν πρέπει να εκτελούνται από παιδιά χωρίς επιτήρηση.

- Το προϊόν δεν είναι παιχνίδι και πρέπει να τοποθετείται σε σημεία στα οποία δεν έχουν πρόσβαση παιδιά. Τα παιδιά δεν έχουν επίγνωση των κινδύνων που σχετίζονται με το χειρισμό ηλεκτρικών συσκευών.

⚠ ΚΙΝΔΥΝΟΣ! Κίνδυνος ασφυξίας!

Τα παιδιά μπορεί να καταπιούν τα παρεχόμενα μικρά μέρη (π.χ. βίδες) με αποτέλεσμα να προκύψει πνιγμός. Μην επιτρέπετε σε παιδιά να πλησιάζουν στην περιοχή εργασίας κατά τη συναρμολόγηση.

- Μην χρησιμοποιείτε το προϊόν αν έχει εμφανείς ζημιές.
- Μην βυθίζετε ποτέ το προϊόν σε νερό ή άλλα υγρά!
- Μην τροποποιείτε και μην επισκευάζετε το προϊόν. Η ενσωματωμένη μονάδα LED και ο ενσωματωμένος οδηγός LED δεν μπορούν να αντικατασταθούν.
- Αν οι λυχνίες LED δεν λειτουργούν στο τέλος της διάρκειας ζωής τους, απαιτείται αντικατάσταση ολόκληρου του προϊόντος.

- Το καλώδιο τροφοδοσίας αυτού του προϊόντος δεν μπορεί να αντικατασταθεί. Αν το καλώδιο τροφοδοσίας υποστεί ζημιά, θα πρέπει να απορριφτεί το προϊόν.



Κίνδυνος για τη ζωή λόγω ηλεκτροπληξίας

- Πριν από κάθε σύνδεση στο ηλεκτρικό δίκτυο ελέγχετε το προϊόν για τυχόν βλάβες. Μην χρησιμοποιείτε ποτέ το προϊόν αν διαπιστώσετε οποιαδήποτε βλάβη.
- Προστατεύστε το καλώδιο τροφοδοσίας από αιχμηρές ακμές, μηχανικά φορτία και πολύ θερμές επιφάνειες.
- Βγάξτε πάντα το φις από τη πρίζα πριν από τον καθαρισμό.
- Αποσυνδέστε το προϊόν από το ηλεκτρικό δίκτυο αν δεν σκοπεύετε να το χρησιμοποιήσετε για μεγάλο χρονικό διάστημα (π.χ. λόγω διακοπών).
- Βεβαιωθείτε ότι η τοπική τάση δικτύου συμφωνεί με την απαιτούμενη τάση λειτουργίας του προϊόντος (230 V~, 50 Hz) πριν το χρησιμοποιήσετε. Σε διαφορετική περίπτωση μην χρησιμοποιείτε το προϊόν.

⚠ ΠΡΟΣΟΧΗ! Κίνδυνος εγκαύματος! Για την αποφυγή εγκαυμάτων, βεβαιωθείτε ότι το προϊόν είναι απενεργοποιημένο και έχουν περάσει τουλάχιστον 15 λεπτά από τη στιγμή που απενεργοποιήθηκε πριν το αγγίξετε. Το προϊόν μπορεί να θερμανθεί πολύ.

- Η προσβάσιμη επιφάνεια θερμαίνεται πολύ όταν η λυχνία βρίσκεται σε λειτουργία.



ΚΙΝΔΥΝΟΣ ΠΥΡΚΑΓΙΑΣ!

Τοποθετήστε το προϊόν κατά τέτοιον τρόπο, ώστε να απέχει τουλάχιστον 1,0 μέτρο από το αντικείμενο φωτισμού. Η ανάπτυξη υπερβολικής θερμότητας μπορεί να οδηγήσει σε πυρκαγιά.

- **⚠ ΠΡΟΕΙΔΟΠΟΙΗΣΗ!** Μην ανάβετε τον προβολέα προσανατολισμένο σε εύφλεκτη επιφάνεια. Μπορεί η επιφάνεια να υπερθερμανθεί ή να ανάψει από την ακτινοβολία.
- Μην τοποθετείτε αναμμένα κεριά ή άλλες γυμνές φλόγες πάνω ή κοντά στο προϊόν.
- Μην χρησιμοποιείτε το προϊόν κοντά σε πηγές θερμότητας, όπως π.χ. θερμαντικά σώματα ή άλλες συσκευές που εκπέμπουν θερμότητα.
- Το προϊόν πρέπει να χρησιμοποιείται μόνο με ενσωματωμένο στραγγαλιστικό πηνίο LED.
- Ακόμη και όταν το προϊόν απενεργοποιείται, εξακολουθεί να καταναλώνει μια ελάχιστη ποσότητα ισχύος όταν παραμένει συνδεδεμένο στο ηλεκτρικό δίκτυο. Για πλήρη απενεργοποίηση αποσυνδέστε το φις από την πρίζα.
- Το φις πρέπει να συνδέεται μόνο σε πρίζα με ίδιο βαθμό προστασίας IP για τη διατήρηση του βαθμού προστασίας από σκόνη/νερό.
- Οι λάμπες δεν πρέπει να συνδέονται σε σειρά.
- Μπορείτε είτε να αναρτήσετε το προϊόν είτε να το τοποθετήσετε σε μια επίπεδη, σταθερή επιφάνεια, όπως ένα δάπεδο ή ένα τραπέζι.
- Το προϊόν δεν πρέπει να χρησιμοποιείται ως λάμπα χειρός.

- Μην τοποθετείτε το προϊόν σε τοίχο ή οροφή. Το προϊόν επιτρέπεται να χρησιμοποιείται μόνο όπως περιγράφεται στις παρούσες οδηγίες χρήσης.

● **Θέση σε λειτουργία**

● **Αποσυσκευασία προϊόντος**

1. Αφαιρέστε το προϊόν από τη συσκευασία. Αφαιρέστε όλα τα υλικά συσκευασίας και τις προστατευτικές μεμβράνες.
2. Ελέγξτε αν διατίθενται όλα τα μέρη και αν το περιγραφόμενο περιεχόμενο συσκευασίας είναι πλήρες (βλ. «Περιεχόμενο συσκευασίας»).
3. Ελέγξτε αν το προϊόν και όλα τα μέρη βρίσκονται σε καλή κατάσταση. Αν διαπιστώσετε ζημιές ή ελαττώματα, μην χρησιμοποιείτε το προϊόν. Ακολουθήστε τις οδηγίες του κεφαλαίου «Εγγύηση».

● **Τοποθέτηση του προϊόντος**

(Εικ. C, D)

⚠ ΠΡΟΣΟΧΗ! Κίνδυνος τραυματισμού!

Δώστε προσοχή στη θέση των χεριών σας όταν ανοίγετε ή κλείνετε το πόδι στήριξης [6]. Υπάρχει κίνδυνος σύνθλιψης των δαχτύλων σας.

1. Χαλαρώστε και τους δύο κοχλίες με αστεροειδή λαβή [2].
2. Αναδιπλώστε το πόδι στήριξης [6] μέχρι τέρμα (περ. 90°).
3. Σφίξτε και τους δύο κοχλίες με αστεροειδή λαβή [2].
4. Τοποθετήστε το προϊόν σε σταθερή, οριζόντια επιφάνεια.
5. Ελέγξτε τη σταθερότητα του προϊόντος.

● **Χρήση**

● **Ενεργοποίηση και απενεργοποίηση του προϊόντος**

⚠ ΕΠΙΦΥΛΑΚΗ! Κίνδυνος υλικής ζημιάς! Μην κουνάτε το καλώδιο τροφοδοσίας [8] του προϊόντος μετά τη σύνδεση του φικ σε πρίζα. Υπάρχει κίνδυνος το προϊόν να γλιστρήσει ή να πέσει.

ⓘ ΠΛΗΡΟΦΟΡΙΕΣ: Συνδέστε το φικ [8] σε πρίζα IPX4, όταν χρησιμοποιείτε το προϊόν σε εξωτερικούς χώρους.

Συνδέστε το φικ [8] σε κατάλληλη πρίζα.

Ενεργοποίηση: Μετακινήστε το διακόπτη ενεργοποίησης/ απενεργοποίησης [5] στη θέση **I** (κανονική φωτεινότητα) ή στη θέση **II** (μέγιστη φωτεινότητα).

Απενεργοποίηση: Μετακινήστε το διακόπτη ενεργοποίησης/ απενεργοποίησης [5] στη θέση **O**.

● **Σύνδεση εξωτερικής συσκευής στην πρίζα**

⚠ ΠΡΟΕΙΔΟΠΟΙΗΣΗ! Κίνδυνος πυρκαγιάς! Μην συνδέετε συσκευή, της οποίας η συνολική κατανάλωση ισχύος υπερβαίνει τα 2500 W.

⚠ ΠΡΟΕΙΔΟΠΟΙΗΣΗ! Κίνδυνος ηλεκτροπληξίας! Είναι δυνατή η εισροή νερού στο προϊόν, εάν συνδέσετε μια συσκευή με ένα μη αδιάβροχο φικ. Εάν χρησιμοποιείτε το προϊόν σε εξωτερικούς χώρους, βεβαιωθείτε ότι η συσκευή που πρόκειται να συνδεθεί στην πρίζα [3] διαθέτει αδιάβροχο φικ.

■ Η πρίζα [3] προστατεύεται μόνο σύμφωνα με το IPX4.

■ Συνδέετε μόνο φικ IPX4 που είναι κατάλληλο για εξωτερικούς χώρους.

1. Ανοίξτε το κάλυμμα πρίζας **4**.
2. Συνδέστε το φις της συσκευής σας στην πρίζα **3**.
3. Βγάλτε το φις της συσκευής σας από την πρίζα **3** μετά από τη χρήση. Κλείστε το κάλυμμα πρίζας **4**.

● Καθαρισμός

- Μην βυθίζετε ποτέ το προϊόν σε νερό ή σε άλλα υγρά. Διαφορετικά μπορεί να προκληθεί ζημιά στο προϊόν.
- Πριν τον καθαρισμό:
 - Βγάλτε το φις **8** από την πρίζα.
 - Αφήστε το προϊόν να κρυώσει.
 - Κλείστε το κάλυμμα πρίζας **4**.
- Καθαρίστε το προϊόν με ένα ελαφρώς υγρό πανί χωρίς χνούδι και ήπιο απορρυπαντικό.

● Απόσυρση

Η συσκευασία αποτελείται από υλικά φιλικά προς το περιβάλλον, τα οποία μπορείτε να διαθέσετε στους χώρους ανακύκλωσης της περιοχής σας.



Προσέξτε τον χαρακτηρισμό των υλικών συσκευασίας για τον διαχωρισμό απορριμμάτων, αυτά είναι χαρακτηρισμένα από συντόμευσεις (a) και αριθμούς (b) με την ακόλουθη σημασία: 1–7: πλαστικά/20–22: χαρτί και χαρτόνι/80–98: σύνθετο υλικό.

Προϊόν:



Για πληροφορίες σχετικά με τις δυνατότητες απόρριψης του προϊόντος που δεν χρησιμοποιείται πλέον, απευθυνθείτε στις αρμόδιες υπηρεσίες της κοινότητας ή του δήμου σας.



Για την προστασία του περιβάλλοντος, μην απορρίπτετε το άχρηστο πλέον προϊόν στα οικιακά απορρίμματα, αλλά παραδώστε το στα ειδικά Κέντρα απόρριψης. Για τα σημεία συλλογής και τις ώρες λειτουργίας τους απευθυνθείτε στις αρμόδιες υπηρεσίες.

● Εγγύηση

Το προϊόν κατασκευάστηκε σύμφωνα με αυστηρές κατευθυντήριες οδηγίες ποιότητας και ελέγχθηκε επιμελώς πριν από την παράδοση. Σε περίπτωση ελαττώματος υλικού ή κατασκευής, έχετε νόμιμα δικαιώματα έναντι του πωλητή του προϊόντος. Τα νομικά σας δικαιώματα δεν περιορίζονται με οιονδήποτε τρόπο από την αναφερόμενη παρακάτω εγγύηση.

Η εγγύηση για το προϊόν αυτό ανέρχεται σε 3 έτη από την ημερομηνία αγοράς. Ο χρόνος εγγύησης αρχίζει την ημερομηνία αγοράς. Φυλάξτε τη γνήσια απόδειξη αγοράς σε σίγουρο μέρος, καθώς αυτό το έγγραφο απαιτείται ως αποδεικτικό της αγοράς.

Όλες οι ζημιές ή τα ελαττώματα, τα οποία υπάρχουν ήδη κατά τον χρόνο της αγοράς, πρέπει να αναφέρονται χωρίς καθυστέρηση μετά την αποσυσκευασία του προϊόντος.

Σε περίπτωση που εντός διαστήματος 3 ετών από την ημερομηνία αγοράς αυτό το προϊόν πασουςιάσει κάποιο ελάττωμα υλικού ή κατασκευής, το προϊόν επισκευάζεται ή αντικαθίσταται από εμάς δωρεάν κατά τη δική μας επιλογή. Ο χρόνος εγγύησης δεν επεκτείνεται λόγω παροχής ικανοποίησης από την ευθύνη για πραγματικά ελαττώματα. Αυτό ισχύει και για εξαρτήματα τα οποία έχουν αντικατασταθεί ή επισκευαστεί.

Αυτή η εγγύηση παύει να ισχύει, εάν στο προϊόν προκλήθηκε ζημιά, ή εάν αυτό χρησιμοποιήθηκε ή συντηρήθηκε με μη ενδεδειγμένο τρόπο.

Η εγγύηση καλύπτει ελαττώματα στο υλικό και την κατασκευή. Αυτή η εγγύηση δεν αφορά σε μέρη του προϊόντος, τα οποία υπόκεινται σε φυσιολογική φθορά και συνεπώς θεωρούνται αναλώσιμα (π.χ., μπαταρίες, επαναφορτιζόμενες μπαταρίες, εύκαμπτοι σωλήνες, φυσίγγια χρώματος), ούτε σε ζημιές σε εύθραυστα εξαρτήματα, όπως διακόπτες ή γυάλινα εξαρτήματα.

Με την αντικατάσταση της συσκευής, σύμφωνα με το ΝΟΜΟΣ 2251/1994, ξεκινάει εκ νέου ο χρόνος εγγύησης.

● Διεκπεραίωση της εγγύησης

Για να διασφαλιστεί η γρήγορη επεξεργασία του αιτήματός σας, ακολουθήστε τις παρακάτω υποδείξεις:

Για όλα τα ερωτήματα έχετε πρόχειρη την ταμειακή απόδειξη και τον αριθμό προϊόντος (IAN 465735_2404) ως αποδεικτικό της αγοράς.

Ο αριθμός προϊόντος αναγράφεται στην πινακίδα τύπου που υπάρχει στο προϊόν, είναι χαραγμένη στο προϊόν, στο εξώφυλλο αυτών των οδηγιών (κάτω αριστερά) ή στο αυτοκόλλητο στην πίσω ή κάτω πλευρά του προϊόντος.

Σε περίπτωση που προκύψουν σφάλματα λειτουργίας ή άλλου είδους ελαττώματα, επικοινωνήστε αρχικά μέσω τηλεφώνου ή email με το τμήμα εξυπηρέτησης που αναφέρεται παρακάτω.

Ένα προϊόν που καταγράφεται ως ελαττωματικό, μπορείτε κατόπιν να το αποστείλετε χωρίς ταχυδρομικά τέλη στην γνωστοποιημένη σε εσάς διεύθυνση εξυπηρέτησης πελατών, επισυνάπτοντας την απόδειξη αγοράς (ταμειακή απόδειξη) και υποδεικνύοντας ποιο είναι το ελάττωμα και πότε εμφανίστηκε.



Στη διεύθυνση parkside-diy.com μπορείτε να κατεβάσετε αυτό και πολλά άλλα εγχειρίδια. Με αυτόν τον κωδικό QR, θα μεταβείτε απευθείας στη σελίδα parkside-diy.com. Επιλέξτε τη χώρα σας και, μέσω της μάσκας αναζήτησης, αναζητήστε τις οδηγίες χρήσης. Καταχωρώντας τον αριθμό προϊόντος (IAN) 465735_2404 θα μεταβείτε στις οδηγίες χρήσης για το προϊόν σας.

● Σέρβις

GR Σέρβις Ελλάδα

Τηλ: 00800 491800674

Email: owim@lidl.gr

CY Σέρβις Κύπρος















Τηλ: 8009 4211

Email: owim@lidl.com.cy



Liste der verwendeten Piktogramme/Symbole	Seite	38
Einleitung	Seite	39
Bestimmungsgemäße Verwendung	Seite	39
Lieferumfang	Seite	39
Liste der Teile	Seite	39
Technische Daten	Seite	39
Allgemeine Sicherheitshinweise	Seite	40
Inbetriebnahme	Seite	42
Produkt auspacken	Seite	42
Produkt aufstellen	Seite	42
Verwendung	Seite	42
Produkt ein- und ausschalten	Seite	42
Externes Gerät an die Steckdose anschließen	Seite	42
Reinigung	Seite	43
Entsorgung	Seite	43
Garantie	Seite	43
Abwicklung im Garantiefall	Seite	44
Service	Seite	44

Liste der verwendeten Piktogramme/Symbole

	<p>GEFAHR! – Bezeichnet eine Gefahr mit hohem Risikograd, die, wenn sie nicht vermieden wird, den Tod oder eine schwere Verletzung zur Folge hat (z. B. Erstickungsgefahr)</p>		<p>Wechselstrom/-spannung</p>
	<p>WARNUNG! – Bezeichnet eine Gefahr mit mittlerem Risikograd, die, wenn sie nicht vermieden wird, den Tod oder eine schwere Verletzung zur Folge haben kann (z. B. Stromschlagrisiko)</p>		<p>Staub- und spritzwassergeschützt (IP54) für LED-Arbeitsstrahler (außer Steckdose)</p>
	<p>VORSICHT! – Bezeichnet eine Gefahr mit niedrigem Risikograd, die, wenn sie nicht vermieden wird, eine leichte bis mäßige Verletzung zur Folge haben kann (z. B. Verbrühungsgefahr)</p>		<p>Spritzwassergeschützt (nur Steckdose)</p>
	<p>ACHTUNG! – Warnt vor möglichen Sachschäden (z. B. Kurzschlussrisiko)</p>		<p>Länge der Anschlussleitung: 3 m</p>
	<p>INFO: Dieses Symbol mit dem Signalwort „Info“ bietet weitere nützliche Informationen.</p>		<p>Produkt ist konzipiert, um starken mechanischen Belastungen zu widerstehen</p>
	<p>Minimaler Abstand zu beleuchtetem Material</p>		<p>Sicherheitshinweise Handlungsanweisungen</p>
	<p>Nicht zur Raumbelichtung im Haushalt geeignet</p>		<p>VORSICHT. Heiße Oberfläche!</p>
	<p>Das CE-Zeichen bestätigt Konformität mit den für das Produkt zutreffenden EU-Richtlinien.</p>		

LED-ARBEITSSTRAHLER

● Einleitung

Wir beglückwünschen Sie zum Kauf Ihres neuen Produkts. Sie haben sich damit für ein hochwertiges Produkt entschieden. Die Bedienungsanleitung ist Teil dieses Produkts. Sie enthält wichtige Hinweise für Sicherheit, Gebrauch und Entsorgung. Machen Sie sich vor der Benutzung des Produkts mit allen Bedien- und Sicherheitshinweisen vertraut. Benutzen Sie das Produkt nur wie beschrieben und für die angegebenen Einsatzbereiche. Händigen Sie alle Unterlagen bei Weitergabe des Produkts an Dritte mit aus.

● Bestimmungsgemäße Verwendung

- Dieses Produkt eignet sich für den Einsatz unter rauen Bedingungen.
- Dieses Produkt eignet sich ausschließlich zur privaten Verwendung in Außenbereichen.
- Dieses Produkt ist nicht für den gewerblichen Gebrauch oder andere Anwendungen bestimmt.

● Technische Daten

Modell:	HG12251	HG12251-FR
Eingangsspannung:	230 V~, 50 Hz	
Gesamte Leistungsaufnahme:	100 W	
Schutzklasse:	I	
Ausgangsleistung über die Steckdose:	max. 2 500 W	
1	Staubschutz/Spritzschutz	
2	Spritzschutz	
3	Netzstecker nur zur Verwendung im Innenbereich	
4	Nur bei geschlossener Steckdosenabdeckung (ohne eingesteckten Netzstecker)	

-  Dieses Produkt ist nicht zur Raumbeleuchtung im Haushalt geeignet.

● Lieferumfang

- 1 LED-Arbeitsstrahler
- 1 Bedienungsanleitung

● Liste der Teile

Schlagen Sie vor dem Lesen die Seite mit den Abbildungen auf und machen Sie sich mit allen Funktionen des Produkts vertraut.

- 1 Griff
- 2 Sterngriffschraube
- 3 Steckdose
- 4 Steckdosenabdeckung
- 5 Ein-/Aus-Schalter
- 6 Standfuß
- 7 LED-Panel
- 8 Anschlussleitung mit Netzstecker

Modell:		HG12251	HG12251-FR
Abmessungen:		ca. 36 cm × 35 cm × 8 cm	ca. 36 cm × 35 cm × 7 cm
Gewicht:		ca. 2 500 g	
Projektionsfläche:		973 cm ²	
Zertifizierung:		GS	–
Schutzart	Produkt (außer Steckdose):	IP54 ¹	IP54 ^{1,3}
	Steckdose:	IPX4 ²	IPX4 ^{2,4}
Dieses Produkt enthält eine Lichtquelle der Energieeffizienzklasse „E“.			
¹ Staubschutz/Spritzschutz ² Spritzschutz ³ Netzstecker nur zur Verwendung im Innenbereich ⁴ Nur bei geschlossener Steckdosenabdeckung (ohne eingesteckten Netzstecker)			



Allgemeine Sicherheitshinweise

MACHEN SIE SICH VOR DER VERWENDUNG DES PRODUKTS MIT ALLEN SICHERHEITSHINWEISEN UND GEBRAUCHSANWEISUNGEN VERTRAUT! WENN SIE DIESES PRODUKT AN ANDERE WEITERGEBEN, GEBEN SIE AUCH ALLE DOKUMENTE WEITER!



⚠️ WARNUNG! LEBENSGEFAHR UND UNFALLGEFAHR FÜR SÄUGLINGE UND KINDER!

Lassen Sie Kinder nicht mit dem Verpackungsmaterial unbeaufsichtigt. Halten Sie Kinder immer vom Verpackungsmaterial fern.

- Dieses Produkt kann von Kindern ab 8 Jahren sowie von Personen mit eingeschränkten körperlichen, sensorischen oder geistigen Fähigkeiten oder fehlender Erfahrung und/oder fehlendem Wissen verwendet werden, solange diese beaufsichtigt werden

oder zur sicheren Verwendung des Produktes angewiesen wurden und die damit verbundenen Risiken verstehen. Lassen Sie Kinder nicht mit dem Produkt spielen. Reinigung und Wartung sollten nicht von Kindern ohne Aufsicht durchgeführt werden.

- Dieses Produkt ist kein Spielzeug und muss außerhalb der Reichweite von Kindern gehalten werden. Kinder sind sich der Gefahren in Zusammenhang mit dem Umgang mit Elektrogeräten nicht bewusst.
- ⚠️ **GEFAHR! Erstickungsrisiko!** Kinder können mitgelieferte Kleinteile (z. B. Schrauben) verschlucken und daran ersticken. Halten Sie Kinder während der Montage vom Arbeitsbereich fern.
- Verwenden Sie das Produkt nicht, wenn es sichtbare Schäden aufweist.
- Tauchen Sie das Produkt niemals in Wasser oder andere Flüssigkeiten ein!

- Führen Sie keine Veränderungen oder Reparaturen am Produkt durch. Das eingebaute LED-Modul und der eingebaute LED-Treiber können nicht ausgetauscht werden.
- Wenn die LEDs am Ende ihrer Nutzungsdauer nicht mehr funktionieren, muss das gesamte Produkt ausgetauscht werden.
- Die Anschlussleitung dieses Produkts kann nicht ersetzt werden. Wenn die Anschlussleitung beschädigt ist, muss das Produkt entsorgt werden.



Lebensgefahr durch elektrischen Schlag

- Überprüfen Sie vor jedem Netzanschluss das Produkt auf etwaige Beschädigungen. Benutzen Sie das Produkt niemals, wenn Sie irgendwelche Beschädigungen feststellen.
- Schützen Sie die Anschlussleitung vor scharfen Kanten, mechanischen Belastungen und heißen Oberflächen.
- Ziehen Sie vor der Reinigung den Netzstecker aus der Steckdose.
- Trennen Sie das Produkt vom Stromnetz, wenn Sie es längere Zeit nicht verwenden (z. B. Urlaub).
- Vergewissern Sie sich, dass die vorhandene Netzspannung mit der benötigten Betriebsspannung des Produkts übereinstimmt (230 V~, 50 Hz), bevor Sie es verwenden. Verwenden Sie das Produkt nicht, wenn dies nicht der Fall ist.

VORSICHT! Verbrennungsrisiko!

Um Verbrennungen zu vermeiden, überzeugen Sie sich, dass das Produkt ausgeschaltet und für mindestens 15 Minuten abgekühlt ist, bevor Sie es berühren. Das Produkt kann sehr heiß werden.

- Die zugängliche Oberfläche wird sehr heiß, wenn die Lampe in Betrieb ist.



BRANDGEFAHR! Stellen Sie

das Produkt so auf, dass es mindestens 1,0 Meter von dem zu beleuchtenden Material entfernt ist. Übermäßige Wärmeentwicklung kann zu einem Brand führen.

- **WARNUNG!** Schalten Sie das Licht nicht ein, wenn das Produkt auf eine brennbare Oberfläche gerichtet ist. Die angestrahlte Oberfläche könnte sich überhitzen oder entzünden.
- Stellen Sie keine brennenden Kerzen oder andere offenen Flammen auf oder in die Nähe des Produktes.
- Verwenden Sie das Produkt nicht in der Nähe von Wärmequellen, z. B. Heizkörpern oder anderen Geräten, die Wärme abgeben.
- Das Produkt ist nur mit dem eingebauten LED-Vorschaltgerät zu verwenden.
- Das Produkt nimmt auch dann noch eine geringe Leistung auf, wenn das Produkt zwar ausgeschaltet ist, aber mit der Stromversorgung verbunden ist. Zum vollständigen Ausschalten entfernen Sie den Netzstecker aus der Steckdose.
- Der Netzstecker kann nur mit einer entsprechenden Steckdose mit dem gleichen IP-Schutzgrad verbunden werden, um den Schutzgrad gegen Staub/Wasser zu erhalten.

- Leuchten dürfen nicht nacheinander angeschlossen werden.
- Sie können das Produkt entweder aufhängen oder auf einer ebenen, stabilen Oberfläche, z. B. Boden oder Tisch, aufstellen.
- Das Produkt darf nicht als Handlampe verwendet werden.
- Montieren Sie das Produkt nicht an einer Wand oder einer Decke. Das Produkt darf nur entsprechend der Beschreibung in dieser Bedienungsanleitung verwendet werden.

● **Inbetriebnahme**

● **Produkt auspacken**

1. Entnehmen Sie das Produkt aus der Verpackung. Entfernen Sie sämtliche Verpackungsmaterialien und Schutzfolien.
2. Prüfen Sie, ob alle Teile vorhanden sind und ob der beschriebene Lieferumfang vollständig ist (siehe „Lieferumfang“).
3. Prüfen Sie, ob sich das Produkt und sämtliche Teile in gutem Zustand befinden. Sollten Sie eine Beschädigung oder einen Defekt feststellen, verwenden Sie das Produkt nicht, sondern verfahren Sie wie im Kapitel „Garantie“ beschrieben.

● **Produkt aufstellen**

(Abb. C, D)

⚠ VORSICHT! Verletzungsrisiko! Achten Sie auf die Position Ihrer Hände, während Sie den Standfuß **6** ein- oder ausklappen. Es besteht das Risiko der Quetschung Ihrer Finger.

1. Lösen Sie beide Sterngriffschrauben **2**.
2. Klappen Sie den Standfuß **6** bis zum Anschlag aus (ca. 90°).

3. Ziehen Sie beide Sterngriffschrauben **2** fest.
4. Stellen Sie das Produkt auf eine stabile, waagerechte Oberfläche.
5. Überprüfen Sie die Stabilität des Produkts.

● **Verwendung**

● **Produkt ein- und ausschalten**

⚠ ACHTUNG! Risiko von Sachschäden!

Bewegen Sie die Anschlussleitung **8** des Produkts nicht, nachdem Sie den Netzstecker an eine Steckdose angeschlossen haben. Es besteht das Risiko, dass das Produkt verrutscht oder umkippt.

- i INFO:** Verbinden Sie den Netzstecker **8** mit einer IPX4-Steckdose, wenn Sie das Produkt im Außenbereich verwenden.
 - Verbinden Sie den Netzstecker **8** mit einer geeigneten Steckdose.
 - Einschalten:** Drücken Sie den Ein-/Aus-Schalter **5** in die Position **I** (normale Helligkeit) oder **II** (max. Helligkeit).
 - Ausschalten:** Drücken Sie den Ein-/Aus-Schalter **5** in die Position **O**.

● **Externes Gerät an die Steckdose anschließen**

⚠ WARNUNG! Brandrisiko! Schließen Sie kein Gerät an, dessen gesamte Leistungsaufnahme 2 500 W überschreitet.

⚠️ WARNUNG! Stromschlagrisiko!

Wasser kann in das Produkt eindringen, wenn Sie ein Gerät mit einem nicht wasserdichten Stecker anschließen. Wenn Sie das Produkt im Außenbereich verwenden, vergewissern Sie sich, dass das an die Steckdose **3** anzuschließende Gerät über einen wasserdichten Netzstecker verfügt.

- Die Steckdose **3** ist nur geschützt gemäß IPX4.
 - Stecken Sie nur einen entsprechenden IPX4-Stecker für den Außenbereich ein.
1. Öffnen Sie die Steckdosenabdeckung **4**.
 2. Verbinden Sie den Netzstecker Ihres Geräts mit der Steckdose **3**.
 3. Ziehen Sie nach der Verwendung den Netzstecker Ihres Geräts aus der Steckdose **3**. Schließen Sie die Steckdosenabdeckung **4**.

● **Reinigung**

- Tauchen Sie das Produkt niemals in Wasser oder in andere Flüssigkeiten. Andernfalls kann das Produkt beschädigt werden.
- Vor der Reinigung:
 - Ziehen Sie den Netzstecker **8** aus der Steckdose.
 - Lassen Sie das Produkt abkühlen.
 - Schließen Sie die Steckdosenabdeckung **4**.
- Reinigen Sie das Produkt mit einem fusselfreien, leicht angefeuchteten Tuch und einem milden Reinigungsmittel.

● **Entsorgung**

Die Verpackung besteht aus umweltfreundlichen Materialien, die Sie über die örtlichen Recyclingstellen entsorgen können.



Beachten Sie die Kennzeichnung der Verpackungsmaterialien bei der Abfalltrennung, diese sind gekennzeichnet mit Abkürzungen (a) und Nummern (b) mit folgender Bedeutung: 1–7: Kunststoffe/ 20–22: Papier und Pappe/80–98: Verbundstoffe.

Produkt:



Möglichkeiten zur Entsorgung des ausgedienten Produkts erfahren Sie bei Ihrer Gemeinde- oder Stadtverwaltung.



Werfen Sie Ihr Produkt, wenn es ausgedient hat, im Interesse des Umweltschutzes nicht in den Hausmüll, sondern führen Sie es einer fachgerechten Entsorgung zu. Über Sammelstellen und deren Öffnungszeiten können Sie sich bei Ihrer zuständigen Verwaltung informieren.

● **Garantie**

Das Produkt wurde nach strengen Qualitätsrichtlinien hergestellt und vor der Auslieferung sorgfältig geprüft. Im Falle von Material- oder Herstellungsfehlern haben Sie gegenüber dem Verkäufer des Produkts gesetzliche Rechte. Ihre gesetzlichen Rechte werden in keiner Weise durch unsere unten aufgeführte Garantie eingeschränkt.

Die Garantie für dieses Produkt beträgt 3 Jahre ab Kaufdatum. Die Garantiezeit beginnt mit dem Kaufdatum. Bewahren Sie den Originalkaufbeleg an einem sicheren Ort auf, da dieses Dokument als Nachweis des Kaufs erforderlich ist.

Alle Schäden oder Mängel, die bereits zum Zeitpunkt des Kaufs vorhanden sind, müssen unverzüglich nach dem Auspacken des Produkts gemeldet werden.

Sollte das Produkt innerhalb von 3 Jahren ab Kaufdatum einen Material- oder Herstellungsfehler aufweisen, werden wir es – nach unserer Wahl – kostenlos für Sie reparieren oder ersetzen. Die Garantiezeit verlängert sich durch einen stattgegebenen Gewährleistungsanspruch nicht. Dies gilt auch für ersetzte und reparierte Teile.

Diese Garantie erlischt, wenn das Produkt beschädigt oder unsachgemäß verwendet oder gewartet wurde.

Die Garantie deckt Material- und Herstellungsfehler ab. Diese Garantie erstreckt sich weder auf Produktteile, die normalem Verschleiß unterliegen, und somit als Verschleißteile gelten (z. B. Batterien, Akkus, Schläuche, Farbpatronen), noch auf Schäden an zerbrechlichen Teilen, z. B. Schalter oder Teile aus Glas.

● Abwicklung im Garantiefall

Um eine schnelle Bearbeitung Ihres Anliegens zu gewährleisten, folgen Sie bitte den folgenden Hinweisen:

Bitte halten Sie für alle Anfragen den Kassenbon und die Artikelnummer (IAN 465735_2404) als Nachweis für den Kauf bereit.

Die Artikelnummer entnehmen Sie bitte dem Typenschild am Produkt, einer Gravur am Produkt, dem Titelblatt Ihrer Anleitung (unten links) oder dem Aufkleber auf der Rück- oder Unterseite des Produktes.

Sollten Funktionsfehler oder sonstige Mängel auftreten kontaktieren Sie zunächst die nachfolgend benannte Serviceabteilung telefonisch oder per EMail.

Ein als defekt erfasstes Produkt können Sie dann unter Beifügung des Kaufbelegs (Kassenbon) und der Angabe, worin der Mangel besteht und wann er aufgetreten ist, für Sie portofrei an die Ihnen mitgeteilte Service Anschrift übersenden.



Auf parkside-diy.com können Sie diese und viele weitere Handbücher einsehen und herunterladen. Mit diesem QR-Code gelangen Sie direkt auf parkside-diy.com. Wählen Sie Ihr Land aus, und suchen Sie über die Suchmaske nach den Bedienungsanleitungen. Mittels Eingabe der Artikelnummer (IAN) 465735_2404 gelangen Sie zur Bedienungsanleitung für Ihren Artikel.

● Service

- Ⓛ DE **Service Deutschland**
Tel.: 0800 5435 111
E-Mail: owim@lidl.de
- Ⓛ AT **Service Österreich**
Tel.: 0800 292726
E-Mail: owim@lidl.at
- Ⓛ CH **Service Schweiz**
Tel.: 0800 562153
E-Mail: owim@lidl.ch



OWIM GmbH & Co. KG

Stiftsbergstraße 1
74167 Neckarsulm
GERMANY

Model No.: HG12251

Version: 11/2024

IAN 465735_2404

